

University of Mumbai

Program: _First Year (All Branches) Engineering - SEM-I

Curriculum Scheme: Rev 2019

BEE

Question Bank

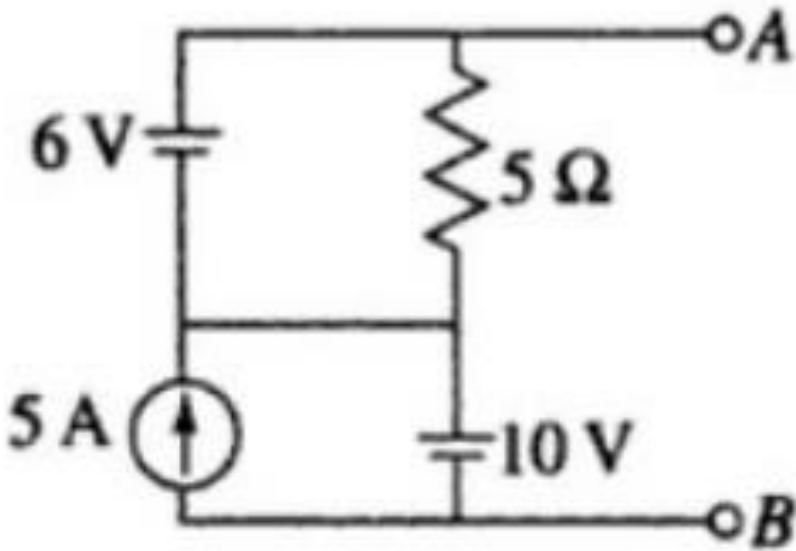
1.	The average and effective values of for a sinusoidal AC waveform are:
Option A:	$V_{avg}=0.637 V_m, V=0.5 V_m$
Option B:	$V_{avg}=0.5 V_m, V=0.5 V_m$
Option C:	$V_{avg}=0.11 V_m, V=0.707 V_m$
Option D:	$V_{avg}=0.637 V_m, V=0.707 V_m$
2.	$V_{AB} = ?$ 
Option A:	6V
Option B:	10V
Option C:	16V
Option D:	4V
3.	An AC voltage is given by the equation $v = 325 \sin 314t$. The RMS and Average value of the voltage are_____ respectively.
Option A:	229.80 V and 207.02 V
Option B:	206.90 V and 229.80 V

Option C:	206.90 V and 206.90 V
Option D:	229.80 V and 229.80 V
4.	If one of the wattmeters shows zero reading (in a two-wattmeter method measurement of three phase power), $\cos\phi$ of the circuit is _____
Option A:	1
Option B:	0
Option C:	0.5
Option D:	0.25
5.	A R-L-C series circuit has a resonant frequency 'f'. If all the component values are doubled, the new resonant frequency is
Option A:	2f
Option B:	4f
Option C:	f/2
Option D:	f/4
6.	In dc circuit, resistor values in delta network that is _____ equivalent to a star Y containing three 120 Ohm resistors is
Option A:	360 Ohms each
Option B:	240 Ohms each
Option C:	180 Ohms each
Option D:	120 Ohms each
7.	The current in 100Ω is _____ A.
	<p>The diagram shows a circuit with a 100V DC voltage source V_S on the left. A resistor $R_1 = 68\ \Omega$ is connected in series with the positive terminal of the source. The circuit then splits into two parallel branches. The upper branch contains resistor $R_2 = 100\ \Omega$. The lower branch contains resistor $R_3 = 120\ \Omega$. The bottom terminals of both R_2 and R_3 are connected to a common ground. The terminals across R_3 are labeled A and B, and the voltage across them is denoted as V_{TH}.</p>
Option A:	0.52
Option B:	0.17
Option C:	0.69
Option D:	0.35

8.	When a three-phase supply is given to the _____ winding, a rotating magnetic field of _____ magnitude is produced.
Option A:	Stator, constant
Option B:	Rotor, variable
Option C:	Stator, variable
Option D:	Rotor, constant
9.	When three equal phase impedances are connected in delta in a three-phase electrical system, the equivalent star impedance is _____ of the delta impedance.
Option A:	Half
Option B:	One-third
Option C:	Equal
Option D:	One-fourth
10.	An ideal voltage source should have _____
Option A:	zero internal resistance
Option B:	infinite source resistance
Option C:	large value of emf
Option D:	low value of emf
11.	If the equation of an alternating voltage is $v=623.5 \sin 323t$ then _____ is the rms voltage and _____ is the average voltage.
Option A:	623.5V, 441V
Option B:	441V, 397V
Option C:	397V, 623.5V
Option D:	623.5V, 397V
12.	Current delivered by 40V is _____
Option A:	6A
Option B:	5A

Option C:	10A
Option D:	4A
13.	_____ type of alternating power is always positive whereas _____ power can be positive or negative depending on the nature of the load.
Option A:	Apparent, active
Option B:	Active, reactive
Option C:	Active, passive
Option D:	Reactive, apparent
14.	If one wattmeter of two wattmeter method for three phase power measurement is equal and opposite to the other wattmeter reading then the power factor of the circuit is _____.
Option A:	1
Option B:	0
Option C:	0.5
Option D:	0.25
15.	_____ and _____ are not parts of three phase as well as single phase induction motor.
Option A:	Brushes, rotor
Option B:	Commutator, stator
Option C:	Brushes, commutator
Option D:	Commutator, rotor
16.	_____ type of winding does not have neutral connection whereas _____ type of winding may or may not have neutral connection,
Option A:	Star, Delta
Option B:	Parallel, Star
Option C:	Series, Delta
Option D:	Delta, Star
17.	The resistance R_L for maximum power transfer is _____.

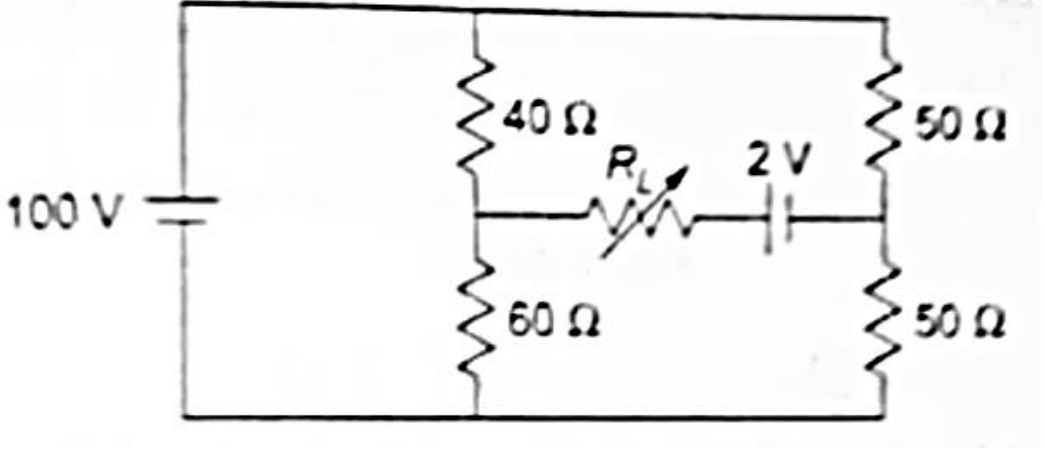
	
Option A:	49 Ω
Option B:	98 Ω
Option C:	70 Ω
Option D:	7 Ω
18.	An inductance of 1H is in series with a capacitance of $1\mu\text{F}$ _____ is the impedance of circuit if the frequency is 50Hz
Option A:	2876 Ω inductive
Option B:	6121 Ω inductive
Option C:	2876 Ω capacitive
Option D:	6121 Ω capacitive
19.	In dc circuit analysis, _____ method has less number of equations compared to _____ method due to the selection of reference voltage.
Option A:	Mesh, Nodal
Option B:	KVL, KCL
Option C:	Nodal, Mesh
Option D:	KCL, KVL
20.	An ideal and practical voltage sources have _____ and _____ internal impedance respectively.
Option A:	Zero, low value
Option B:	Infinite , large value
Option C:	Large value, zero
Option D:	Low value ,infinite
21.	Three identical coils each of $(4.2 + j5.6)$ ohms are connected in star across a 415V. The phase voltage is _____.
Option A:	139.6V
Option B:	439.6V

Option C:	539.6V
Option D:	239.6V
22	In a series R-L-C circuit, $R=2k\Omega$ $L=1H$, $C=1/400\mu F$.The resonant frequency is ____.
Option A:	2×10^4 Hz
Option B:	0.318×10^4 Hz
Option C:	10^4 Hz
Option D:	6.248×10^4 Hz
23	A series RLC circuit will have unity power factor if operated at a frequency of_____.
Option A:	$1/(LC)$
Option B:	$1/w\sqrt{LC}$
Option C:	$1/2w\sqrt{LC}$
Option D:	$1/2\pi\sqrt{LC}$
24	Two currents $I_1 = 10\angle 500A$ and $I_2 = 5\angle -1000A$ flow in a single phase ac circuit. The resultant current is _____
Option A:	$6\angle 26.20^\circ A$
Option B:	$8.2\angle 46.21^\circ A$
Option C:	$9.2\angle 72.21^\circ A$
Option D:	$6.2\angle 26.21^\circ A$
25	Basic elements that cannot be analyzed by ohms law
Option A:	Transistors
Option B:	Resistor
Option C:	Capacitor
Option D:	Inductor
26	According to fundamentals of electrical energy,which of the following is correct about alternating current
Option A:	Frequency is zero
Option B:	Magnitude changes with time
Option C:	Can be transported to larger distances with less loss in power
Option D:	Flows in both the directions
27	Superposition theorem is not applicable to networks containing _____.
Option A:	Non-linear elements
Option B:	Dependent current sources
Option C:	Dependent voltage sources
Option D:	Transformers
28	A network contains only an independent current source and resistors. If all the resistors are doubled, the values of node voltages will be _____.
Option A:	Become half
Option B:	Becomes doubled
Option C:	Remain unchanged

Option D:	Become twice
29	The power consumed by a purely capacitive circuit is _____ and the _____ power is reactive power.
Option A:	1 , circulating
Option B:	0, non-circulating
Option C:	0, circulating
Option D:	1, non-circulating
30	Apparent power is _____ and is expressed in _____.
Option A:	Input, kW
Option B:	Output , kVA
Option C:	Input, kVA
Option D:	Output, kW
31	A series circuit consumes 2000W at 0.5leading power factor when connected to 230V.50Hz ac power supply. The reactive power is _____.
Option A:	4.464kVAR
Option B:	3.764kVAR
Option C:	3.464kVAR
Option D:	4.764kVAR
32	The voltage and current in a circuit are given by $V= 12 \angle 30^0V$ and $I = 3 \angle 60^0A$.The reactance and resistance is _____ and _____.
Option A:	3.46 -j2
Option B:	2.46-j2
Option C:	3.46 +j2
Option D:	2.46 +j2

DESCRIPTIVE QUESTIONS

1.	Show that the average power consumed by a pure capacitor is zero.
2.	Two wattmeters connected to measure the input to a balanced three-phase circuit indicates 2000W and 500W, respectively. Find the total power supplied and the power factor of the circuit: (i) when both the readings are positive and (ii) when the latter reading is obtained after reversing the connections to the current coil.
3.	Determine the current through 12Ω resistor using Source Transformation: <div style="text-align: center;"> </div>
4.	

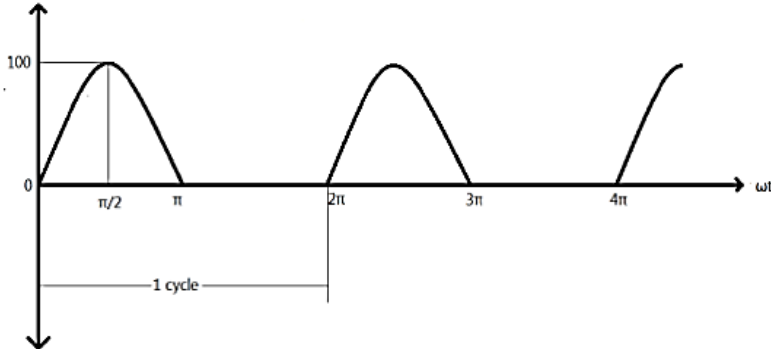
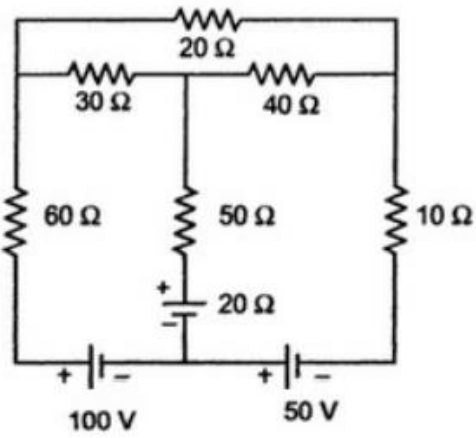
5.	Explain the construction and working of variable reluctance stepper motor.
6.	State and prove Maximum Power Transfer theorem.
7.	<p>Find the average value, rms value, form factor and peak factor for the given waveform:</p> 
8.	<p>A $30\mu\text{F}$ capacitor is connected across a 230V, 50Hz A.C. supply. Calculate:</p> <ol style="list-style-type: none"> Capacitive reactance R.M.S. value of the current flowing through the capacitor Power consumed by the capacitor Power factor Voltage and current time expressions
9.	Explain the principle of operation of a three-phase induction motor.
10.	A series RLC circuit has the following parameters: $R = 10\Omega$, $L = 0.012\text{H}$, $C = 100\mu\text{F}$. Compute the resonant frequency, quality factor (Q), bandwidth, lower and upper cut-off frequencies.
11.	How can you decide the nature of load from the two-wattmeter readings?
12.	<p>Find the current through 50Ω resistor using Mesh Analysis.</p> 

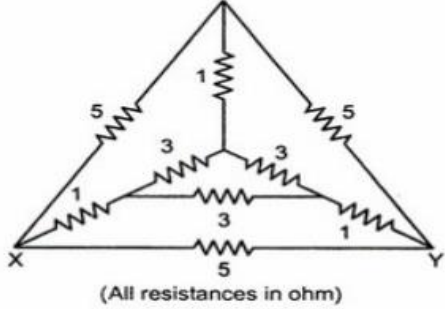
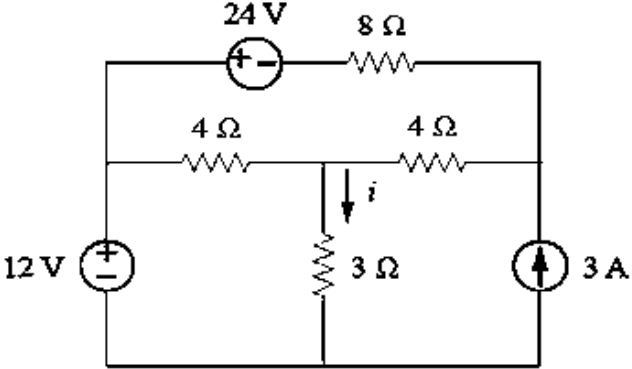
<p>13.</p>	<p>Determine the equivalent resistance between terminals X and Y for the network given below:</p>  <p>(All resistances in ohm)</p>
<p>14.</p>	<p>State Superposition Theorem and find the current 'i' as indicated in the circuit below:</p> 
<p>15.</p>	<p>An imperfect (not pure) capacitor has an impedance of 50Ω and p.f = 0.707 leading. It is connected in series with an external resistance of $R = 40\Omega$ across an A.C supply of 'V' volts and then the current flowing is $I = 3A$. Determine the supply voltage and the overall phase angle.</p>
<p>16.</p>	<p>A 415V, 50Hz, 3-phase voltage is applied to three star connected identical impedances each consisting of series combination of a resistance of 15Ω, inductance 0.1H and capacitance of $177\mu F$. Find:</p> <ol style="list-style-type: none"> phase current line current p.f active, reactive power apparent power
<p>17.</p>	<p>Show that the average power consumed by a pure inductor is zero.</p>
<p>18.</p>	<p>A balanced three phase load consists of three coils, each of resistance 4Ω and inductance 0.02H. Determine the total power when the coils are (i) star connected (ii) delta connected to a 400V, three phase, 50Hz supply.</p>
<p>19.</p>	<p>By source transformation find the current in 3Ω resistor in the following</p>

	<p>circuit.</p>
20.	<p>i) Explain the construction and working of variable reluctance stepper motor. ii) Enlist four applications DC machines.</p>
21.	<p>Find current I in the network using nodal analysis</p>
22.	<p>Find RMS value and peak factor for the following waveform:</p>
23.	<p>A coil of power factor 0.6 is in series with $100\mu\text{F}$ capacitor. When connected to a 50Hz supply, potential difference across coil is equal to potential difference across capacitor, Find resistance and inductance of the coil.</p>
24.	<p>Describe the principle of operation of a single-phase induction motor.</p>
25.	<p>Draw labelled phasor diagrams for three phase star and delta connected systems.</p>
26.	<p>Explain with diagram construction and working of 3 phase induction motor.</p>
27.	<p>Find current in $20\ \Omega$ resistor using mesh analysis.</p>
28.	<p>A resistance and a capacitance connected in series across a 250V supply draws 5A at 50Hz. When frequency is increased to 60Hz, it draws 5.8A. Find the values of R and C. Also find active power and power factor in both cases.</p>
29.	<p>Explain with the neat phasor diagram how two wattmeters can be used to measure power in a 3-Φ system.</p>

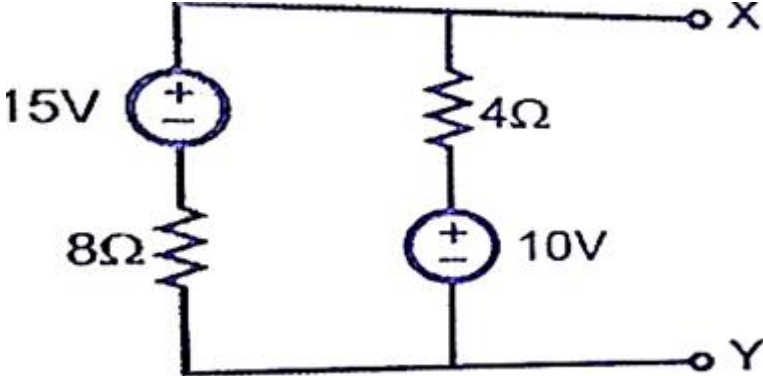
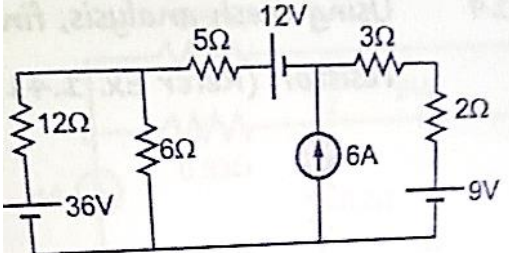
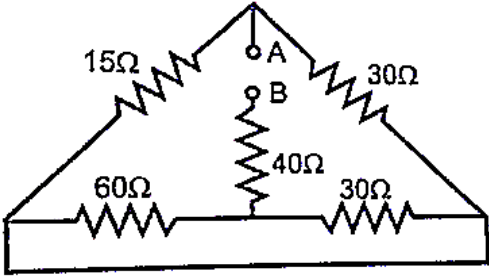
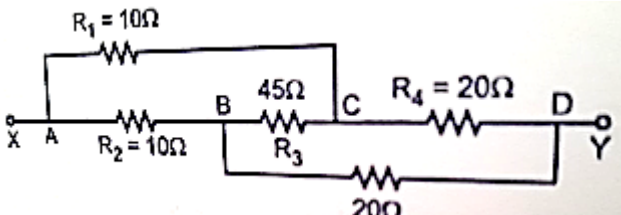
30.	Each phase of a delta connected load consists of a 50mH inductor in series with a parallel combination of a 5Ω resistor and a 5μ capacitor. The load is connected to a three phase, 550V, 50Hz A.C. supply
31.	Compare core type and Shell type transformers.
32.	Derive the E.M.F equation of a transformer.
33.	State and prove maximum power transfer theorem.
34.	<p>Using source transformation convert the following circuit into a single voltage source in series with a resistor.</p> 
35.	<p>Using mesh analysis find the current through 5Ω resistor</p> 
36.	<p>Calculate R_{AB}</p> 
37.	<p>Calculate R_{XY} for the circuit shown in figure below.</p> 
38.	<p>A total current of 10A flows through the parallel combination of three impedances $(2-5j)\Omega$, $(6+3j)$ and $(3+4j)\Omega$. Calculate the current flowing through each branch. Find also the pf of the combination.</p>

39.	A series resonant circuit has an impedance of 500Ω at resonant frequency. The cut-off frequency observed are 10kHz and 100Hz Determine: <ol style="list-style-type: none">1. Resonant frequency2. Value R, L and C3. Q factor at resonance
40.	A voltage of 150V, 50Hz is applied to a coil of negligible resistance and inductance 0.2H. Write the equation of voltage and current.