

Duration: 3 Hours

Max. Marks: 80

**Instructions:**

1. Question number 1 is compulsory.
2. Attempt any three questions from the remaining five questions.
3. Assume suitable data wherever necessary.
4. Figure to the right indicates full marks.

**Q1. Attempt any four questions.**

**[20]**

- a) Construct Signal Flow Graph for the following set of equation.  
 $Y_2 = G_1 Y_1 - G_2 Y_4$   
 $Y_3 = G_3 Y_2 + G_4 Y_3$   
 $Y_4 = G_5 Y_1 + G_6 Y_3$   
 Where  $Y_4$  is the output.
- b) Distinguish between open loop and closed loop control systems.
- c) Explain in short, any three criteria for selection of transducers.
- d) Explain how stability of a system can be predicted by using Gain Margin and Phase Margin.
- e) Draw and explain in brief the block diagram of a Data Acquisition System.

**Q2.**

- a) For the block diagram shown below calculate the transfer function  $Y(s)/R(s)$  using [block diagram reduction technique.

**[10]**

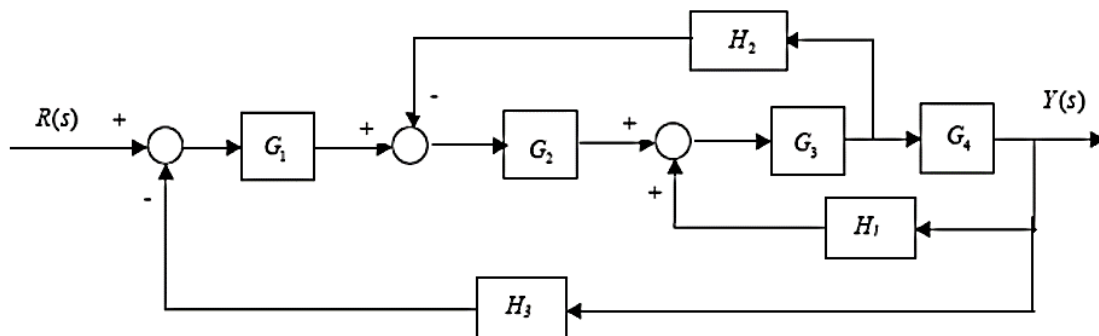

- b) For the characteristic equation given below, calculate the range of  $k$  (if any) for a stable, unstable and marginally stable system. Also calculate the frequency of the system when system is marginally stable.

**[10]**

Characteristic Equation:  $s^4 + 5s^3 + 5s^2 + 4s + k = 0$

**Q3.**

- a) Draw the Root Locus for the system and comment on the stability. [10]

$$G(s)H(s) = \frac{k(s+3)}{s(s+1)(s+2)(s+4)}$$

- b) What is LVDT? With neat diagram explain the principle of working and construction of LVDT. Also explain its application in displacement measurement. [10]

**Q4.**

- a) For system having transfer function  $\frac{25}{s^2+6s+25}$  calculate [10]

- (i) rise time
- (ii) peak time
- (iii) maximum peak overshoot
- (iv) settling time

- b) List the types of temperature transducers and hence explain the principle of working, construction and application of RTD in detail with proper diagram [10]

**Q5.**

- a) Draw the Bode plot and hence find the gain margin and phase margin of the system and comment on the stability. [10]

$$G(s)H(s) = \frac{10}{s(s+4)(s+10)}$$

- b) Draw and explain different type of telemetry system with block diagram. [10]

**Q6. Attempt any four questions.**

[20]

- a) Write short note on strain gauge.
- b) For a type 0 system, write the values for error constants and steady state error with unit step, unit ramp and unit parabolic input
- c) Write short note on fiber optic instrumentation.
- d) Write short note on MODBUS protocol.
- e) Write a short note on SCADA.
- f) Write short note on adaptive control systems.

-----x-----