

Duration: 3hrs

[Max Marks:80]

- N.B. : (1) Question No 1 is Compulsory.
 (2) Attempt any three questions out of the remaining five.
 (3) All questions carry equal marks.
 (4) Assume suitable data, if required and state it clearly.

Q1. All the questions are compulsory

- a. Find the value of V_x (5)

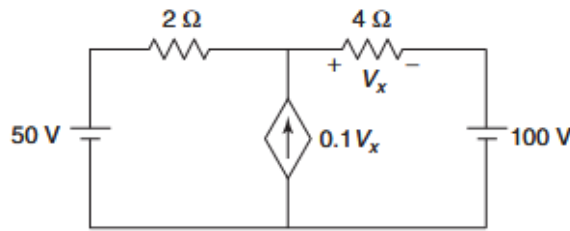

- b. The reduced incidence matrix of an oriented graph is given below. Find the possible number of trees. (5)

$$A = \begin{bmatrix} 0 & -1 & 1 & 1 & 0 \\ 0 & 0 & -1 & -1 & -1 \\ -1 & 0 & 0 & 0 & 1 \end{bmatrix}$$

- c. Draw the pole zero plot for I_0/I_1 (5)

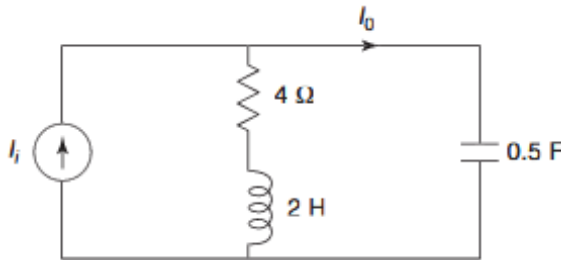

- d. Find Z parameters for the following two port network (5)

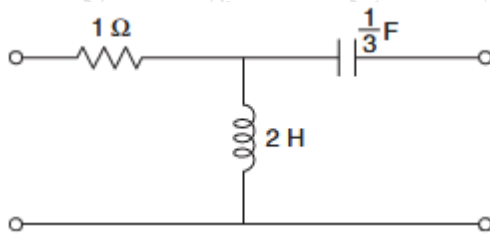

Q2. Solve the following

- a. Find the value of maximum power transferred to the load of 1Ω (10)

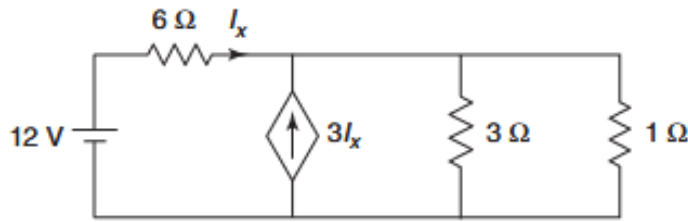

- b. Write incidence matrix, tieset matrix and cutset matrix (10)

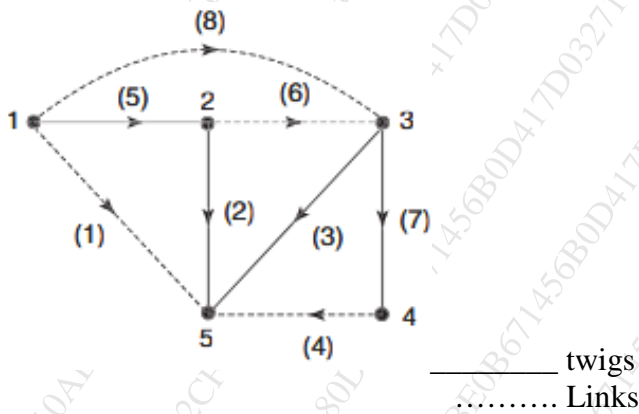

Q3. Solve the following

- a. The switch is changed from the position 1 to the position 2 at $t = 0$, steady condition having reached before switching. Find the values of i , $\frac{di}{dt}$, $\frac{d^2i}{dt^2}$ at $t=0^+$ (10)

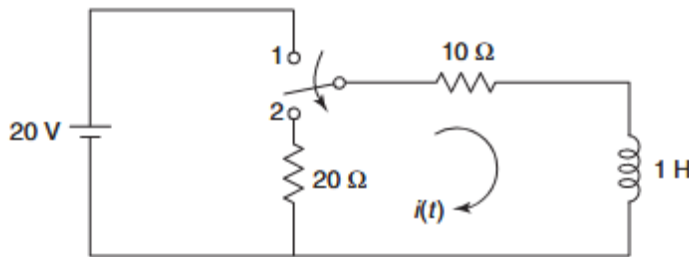

- b. Find h parameters for the following network. State whether given network is reciprocal or not. (10)

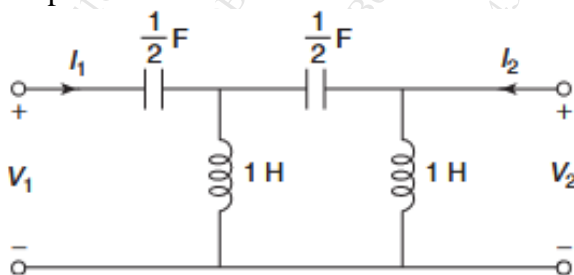

Q4. Solve the following

- a. Steady state is reached with the switch closed. The switch is opened at $t = 0$. Obtain expressions for $i_L(t)$ Obtain the expression **(10)**

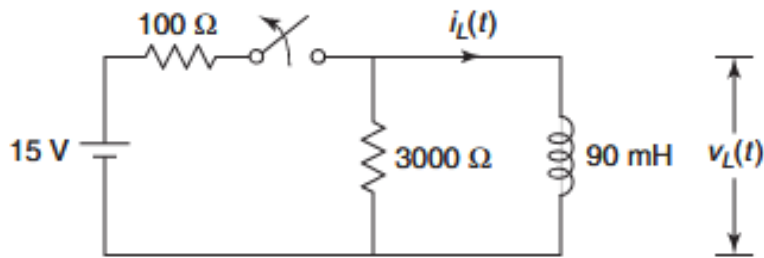

- b. Find the voltage V_x using superposition theorem **(10)**

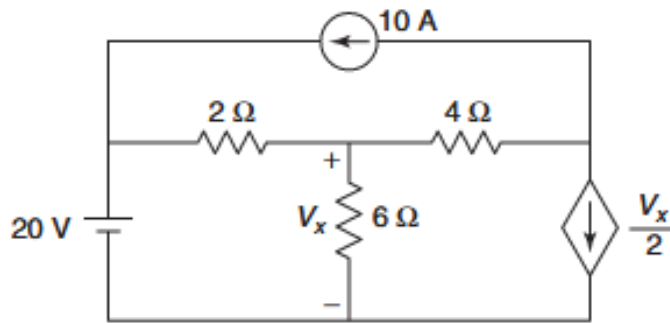

Q5. Solve the following

- a. Find the Y parameters for the network shown **(10)**

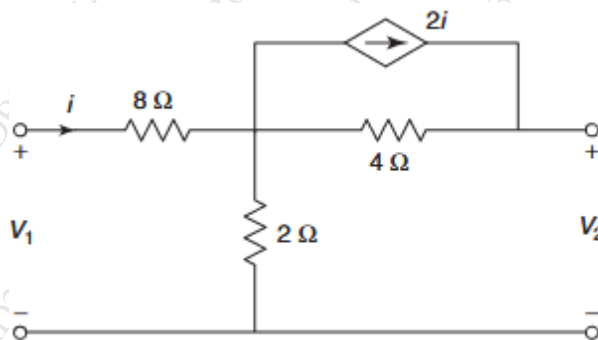

- b. A driving-point impedance $Z(s)$ for the network is as shown. Calculate the values of the parameters R , L , G and C if $Z(j0) = 1$. The poles are located at $-3 \pm j3$ and zero at -2 (10)

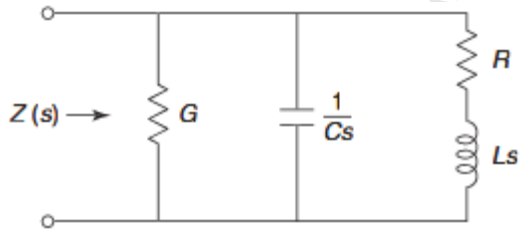

Q6. Solve the following

- a. Find the current I using supermesh theorem (10)

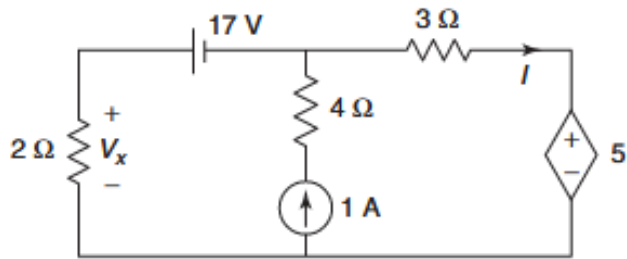

- b. For the network shown, determine $Z_{11}(s)$, $G_{12}(s)$ and $Z_{12}(s)$ (10)

