

Time: 3 Hours

Max. Marks: 80

Q1 is compulsory. Attempt any three from Q2 to Q6.

Q1

Solve any Four

5 marks each

- A Explain the operation of a semiconductor pn junction diode with the help of VI characteristics.
- B Explain Miller's capacitance theorem.
- C Compare BJT CE amplifier and JFET CS amplifier.
- D What is crossover distortion in Class B power amplifiers?
- E Let $V_{DD} = 5V$, $V_{t,1} = 1V$, $k_{n,1}' = 20\mu A/V^2$ and $R = 1K\Omega$. What should be $(W/L)_1$ needed for creating $I_{ref} = 1mA$? What should be $(W/L)_2$ if $I_o = 7mA$? Refer Fig. 1

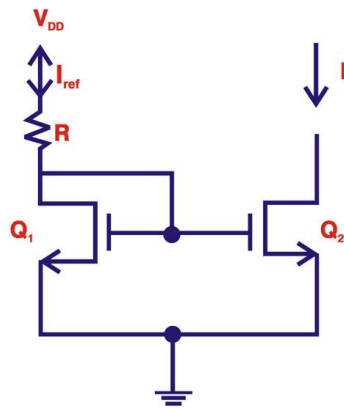

Fig. 1

Q2

10 marks each

- A Design a feedback bias circuit for n-channel E-MOSFET with operating drain current of 0.5 mA. Given: $V_{DD} = 5V$, $k_n' = 100\mu A/V^2$, $W = 1.8\mu m$, $L = 180nm$, $V_{T0n} = 1V$. Use a standard resistor value for R_D and recalculate I_D and V_D . Refer fig. 2.

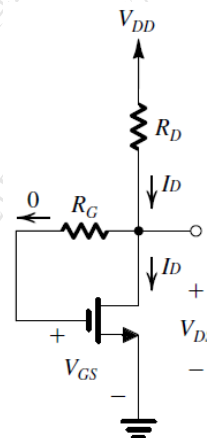

Fig. 2

- B Draw a small signal equivalent circuit of an E-MOSFET CS amplifier given in fig. 3 and derive the expression for voltage gain, input resistance and output resistance.

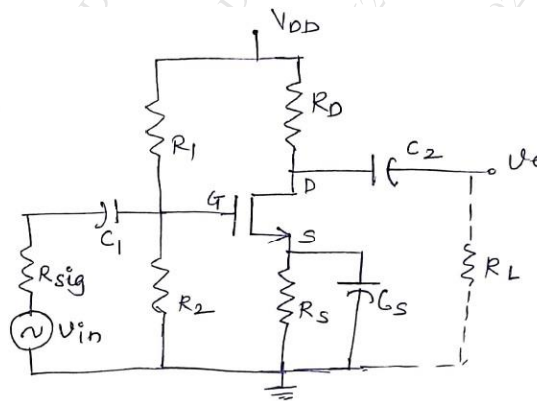

Fig. 3

Q3

- A Explain construction and working of n-channel E-MOSFET **5 marks**
 B What is thermal runaway and how it can be avoided? **5 marks**
 C Calculate low cutoff frequencies due to coupling and bypass capacitors of the circuit given in fig. 4 **10 marks**

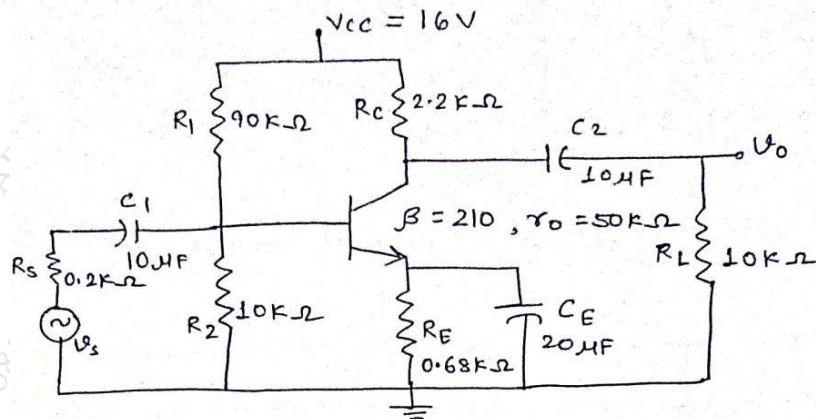

Fig. 4

Q4

- A Determine f_{β} and f_T for the given circuit. Assume $I_E = 1.65$ mA. Refer Fig. **5 marks**

$R_s = 1 \text{ k}\Omega, R_1 = 40 \text{ k}\Omega, R_2 = 10 \text{ k}\Omega, R_E = 2 \text{ k}\Omega, R_C = 4 \text{ k}\Omega, R_L = 2.2 \text{ k}\Omega$
 $C_s = 10 \mu\text{F}, C_c = 1 \mu\text{F}, C_E = 20 \mu\text{F}$
 $h_{fe} = 100, r_o = \infty \Omega, V_{CC} = 20 \text{ V}$
 $C_{\pi}(C_{be}) = 36 \text{ pF}, C_{\mu}(C_{bc}) = 4 \text{ pF}, C_{ce} = 1 \text{ pF}, C_{W_i} = 6 \text{ pF}, C_{W_o} = 8 \text{ pF}$

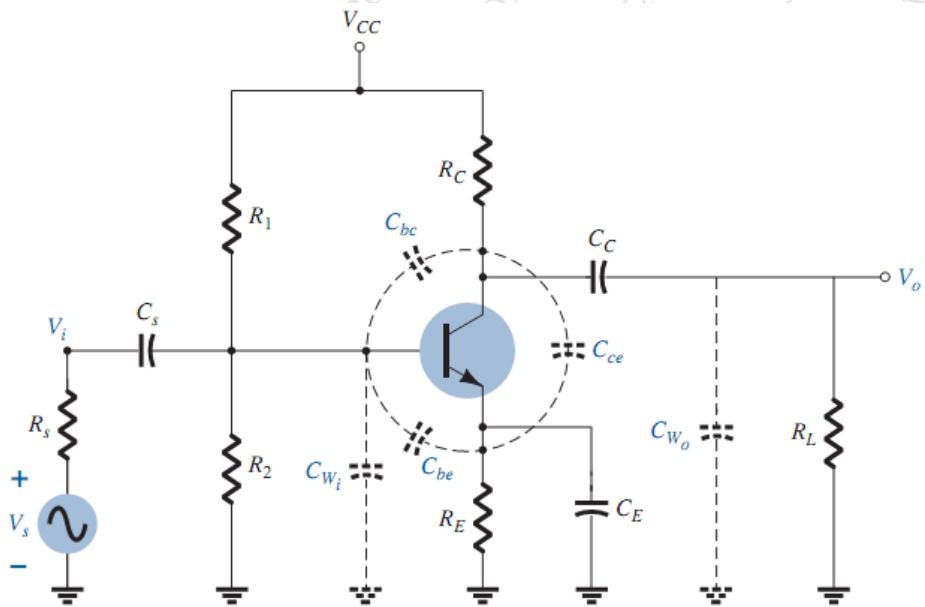

Fig. 5

B Draw and explain high frequency model for BJT in CE configuration.

5 marks

C Draw and explain a series fed class A power amplifier with the help of neat diagram and waveforms and derive the expression of power efficiency.

10 Marks

Q5

A

Design a voltage divider bias circuit to operate at the given conditions.

Calculate the stability factors $S(I_{CO})$, $S(V_{BE})$, $S(\beta)$. Refer Fig. 6 10 Marks

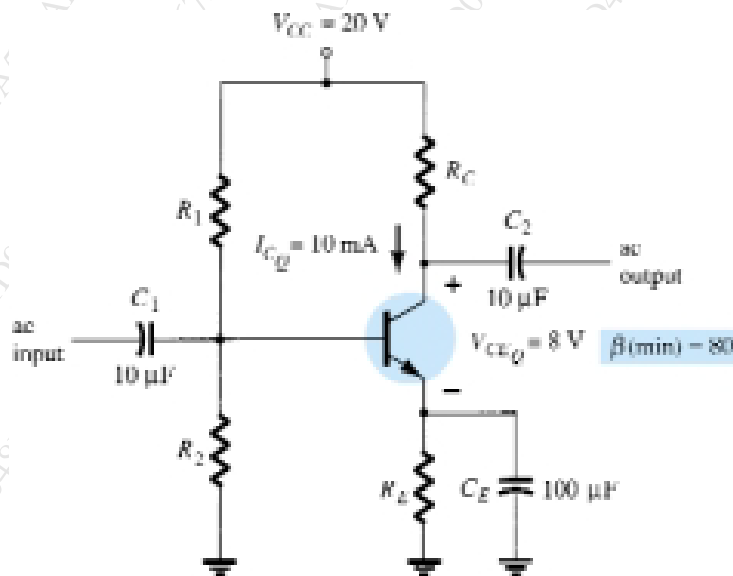

Fig. 6

B Determine the input impedance, output impedance, voltage gain and current gain for the given circuit. Refer fig. 7

10 Marks

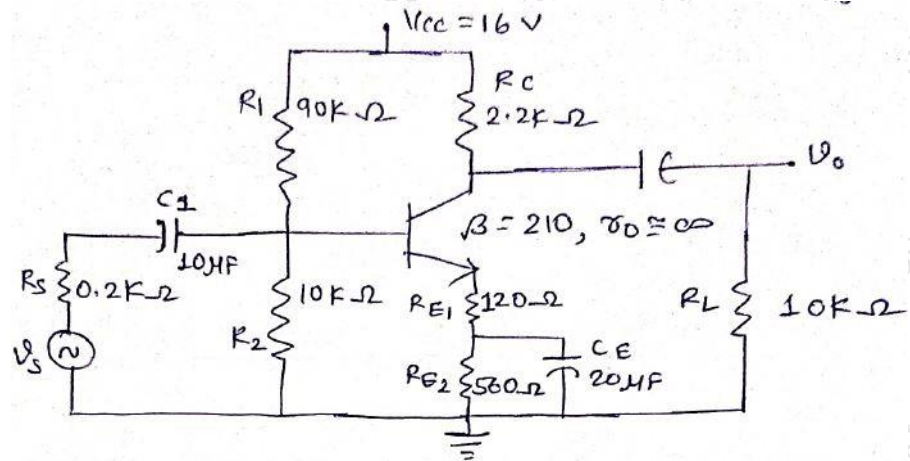

Fig. 7

Q6

- A Derive the equation of CMRR for the MOS differential pair amplifier. **10 Marks**
- B Write short note on:
- i) E-MOSFET as a differential amplifier **5 Marks**
 - ii) Zener diode as a voltage regulator **5 Marks**