

Duration 3 Hours

[Maximum Marks 80]

NOTE:-1) Question 1 is compulsory

- 2) Solve any three from the remaining five questions
- 3) Assume suitable data if necessary.
- 4) Figures to the right indicate full marks

- Q.1. a. Differentiate between closed loop and open loop control system 5
- b. Explain type and order of control system. 5
- c. Explain how to find gain margin and phase margin from Bode plot? 5
- d. Explain any rules in order to plot root locus. 5

- Q.2. a. Find transfer function using Mason's gain formula for shown figure below 10

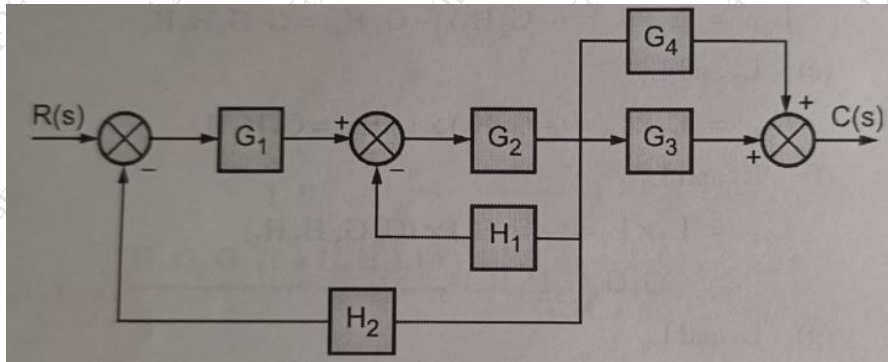

- b. If peak overshoot is 18.3 % and peak time is 0.3023 seconds, 10
Find Damping factor, Undamped natural frequency and Settling time

- Q.3. a. For unity feedback system with open loop transfer function 10

$$G(s) = \frac{100(s+4)}{s^2(s+2)(s+10)}$$

Determine type of system, k_p , k_v , k_a . Find e_{ss} for input $4 + 8t + 2t^2$

- b. For unity feedback system with open loop transfer function 10

$$G(s) = \frac{100}{s(s+8)}$$

Determine damping factor, undamped natural frequency, resonant peak and resonant frequency.

Q.4. a. Explain Lead Compensator design using root locus. **10**

b. Obtain state variable model of transfer function **10**

$$\frac{Y(s)}{R(s)} = \frac{5s + 4}{s^2 + 4s + 3}$$

Q.5. a. The open loop transfer function of the system **10**

$$G(s) H(s) = \frac{4s + 1}{s^2 (s + 1) (2s + 1)}$$

Using Nyquist criterion, examine closed loop stability of the system.

b. Sketch the root locus for open loop transfer function of the system. **10**

$$G(s) H(s) = \frac{k}{s(s + 2)(s^2 + 6s + 25)}$$

Q.6.a. Sketch the Bode plot for open loop transfer function of the system **10**

$$G(s) H(s) = \frac{0.4(1 + 6s)}{s^2(1 + 0.5s)}$$

Also comment on stability.

b. Find the solution of following stste equation **10**

$$\dot{x} = \begin{bmatrix} -5 & -6 \\ 1 & 0 \end{bmatrix} x + \begin{bmatrix} 1 \\ 0 \end{bmatrix} u$$

$$y = [1 \quad 1] x$$
